

*Saint Francis of
Assisi Catholic
Church*



Altar Server Ministry

**Guidelines and Instructions for
Celebration of the Eucharist**

Revised January 2010

Saint Francis of Assisi – Grapevine, Texas

General format at the celebration of the Eucharist

I. INTRODUCTORY RITES

A. THE ORDER OF THE PROCESSION

Ä(S#1-CROSS)

Candle (S#2-BELLS) Candle (S#3-BOOK)

(S#4-GOPHER)

The Book of the Gospel (Deacon or Lector)

Presider

Family of Baptism (If Celebrated)

The procession begins when the choir or cantor sing the first sentence of the song.

Note: If using incense (S#4-GOPHER) will carry the incense with the boat and going in front of the cross. Family of Baptism follows the procession and enters designated pews.

B. AT THE ALTAR IN THE ASSEMBLY LEVEL

Deacon/Lector



(S#4-GOPHER) (S#2-BELLS) Presider (S#3-BOOK) (S#1-CROSS)Ä

The bearer of the Book of the Gospel approaches the altar from the behind of the altar and places the Book of the Gospel on the Altar. All including Gospel bearer make a proper reverence with a profound bow (waist bow) except (S#1-CROSS) is not making a bow. The altar servers holding the candles make a reverence with a bow of the head only. After making a proper reverence, (S#1-CROSS) place the cross in its stand, (S#2-BELLS & S#3-BOOK) place candles in its holder and (S#4-GOPHER) approaches on the left to the seat. Presider and deacon if present approach the Altar and kiss the altar then approach to the chair of the presider.

*** If incensing the altar, (S#4-GOPHER) stands behind and near the altar on the side near the Ambo, assisting the presider in incensing the altar. Remain standing there until the presider gives back the thurible. Then take the thurible and the boat and put them back on the incenser's stand.*

Seating: on the side of the Ambo – (S#4-GOPHER) & (S#2-BELLS) / on the side of Tabernacle – (S#3-BOOK) & (S#1-CROSS)

Sign of respect & reverence during Liturgy – if the Presider bow to you, a returning bow is needed.

C. GREETING & PENITENTIAL & GLORIA & OPENING PRAYER

(S#3-BOOK) picks up the sacramentary from the small table near the Presider's chair and stands on the left side of the presider, holding the sacramentary in front of the chest. Near the end of the Gloria, (S#3-BOOK) goes in front of the presider for opening the sacramentary. After the opening prayer, (S#3-BOOK) places the sacramentary back to the small table near the Presider's chair and proceeds to the seat.

II. LITURGY OF THE WORD

During the liturgy of the Word (First Reading, Psalm, Second Reading) altar servers need to be one with the assembly through listening and singing according to the ritual.

**** For the special seasons (Christmas & Easters) and solemnity, candles and incense will be used for the gospel. Near the end of the second reading, (S#4-GOPHER) goes to the incenser's stand and get the thurible and boat ready. When the choir begins singing Alleluia, (S#4-GOPHER) goes to the presider (Example 1), standing in front of him; while servers (S#2-BELLS and S#3-BOOK) approach the altar from both side and retrieve the candles from the stand and remain standing on both side of the altar. After the Presider puts incense into the thurible, (S#4-GOPHER) moves to the side for deacon to approach the presider for blessing. If no deacon presents, (S#4-GOPHER) follows behind the presider to the altar (Example 2) then to the ambo along with other altar servers standing with candles holding on both side of the ambo (Example 3). After the presider introduces the gospel, he will incense the book of the gospel. When the presider finishes proclaiming the gospel, altar servers put up the candles back to the candle's stand and incenser's stand and be seated. ****

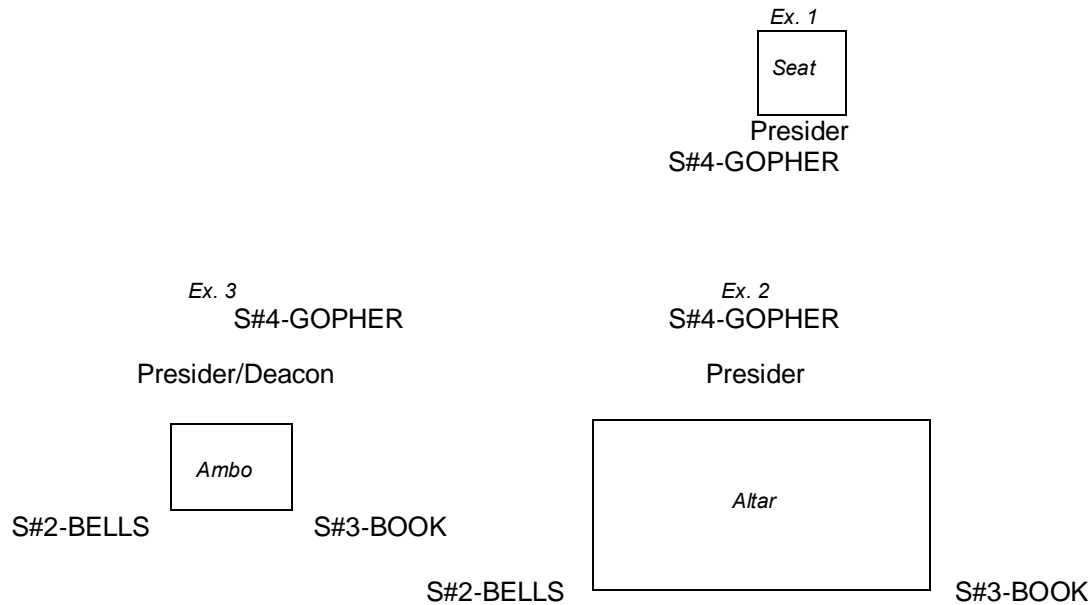

** If there is a baptism at Mass, after the homily (S#3-BOOK) bring the liturgical book to the Presider and assists him by holding the book during the Baptism. When the baptism is done, goes back to the seating.

III. LITURGY OF THE EUCHARIST

A. PREPARATION OF THE ALTAR

No processional cross when people are bringing up the collected gifts.

a. (S#4-GOPHER) brings out the chalice with corporal, pall and purificator and places on the altar on the right side of the altar facing the assembly.

b. (S#3-BOOK) brings the sacramentary and the sacramentary's holder to the altar. The location of sacramentary's holder and the sacramentary should be on the left side of the altar facing the assembly.

c-1. When we **are** using incense during Mass (S#4-GOPHER) gets the thurible and boat and stand by behind the altar. When the Presider finishes offering the gifts and before washing his hands, he will use the incense for incensing the altar. After the Presider finished incensing, if deacon is assisting he will incense the Presider and the people, if there is no deacon, (S#4-GOPHER) will incense the Presider and the people. [How to incense the Presider and the people will be taught at the training].

c-2. When we **are not** using incense during Mass (S#4-GOPHER) gets the cruet of water. Then approaches near the altar on the right side of the altar to assist the Presider pour water into the wine. Then waits for the presider to pour the wine into the cup and take both cruets back.

d. All other servers (S#1-CROSS, S#2-BELLS, S#3-BOOK) go with the Presider to receive the gifts, vocational cross, book of intentions, monetary gift and place them at designated places. Bread and wine will go to the altar. Vocational cross and book of intentions go to the small table near the baptismal font. Monetary gift basket places at the right side of the altar on the sanctuary level.

e. Only when we **are** using incense during Mass (S#2-BELLS) gets the cruet of water after helping the gifts to its locations at the altar. Then approaches near the altar on the right side of the altar to assist the Presider pour water into the wine. Then waits for the presider to pour the wine into the cup and take both cruets back.

f. (S#1-CROSS) and (S#3-BOOK) I prepare the water and towel for the presider to wash his hands. After all done, all altar servers go back to your seating.

B. DURING EUCHARISTIC PRAYER

(S#2-BELLS) prepares to ring the bell at the following moments: (1) when the presider with hands raising above the gifts invoking the Holy Spirit to come, (2) when the presider elevates the host, and (3) when the presider elevates the chalice. During the consecration when the presider elevates the Host and the Chalice up for veneration, altar server rings the bell from the time of lifting up to the time when the presider begins to low it down. Need to look at the Presider's movements.

C. COMMUNION RITE

After praying the Our Father and giving a sign of peace, (S#3-BOOK) takes the sacramentary and the sacramentary's holder back to their places. The sacramentary back to the small table near the Presider's chair and the holder back in the sacristy room, where we keep the candle lighter.

All servers receive communion as usual, be seated and sing the communion with the community. At the end of communion, (S#4-GOPHER) gets the cruet of water and brings it to the altar for purification. Then takes it back and returns to your seating. Be attentive when extraordinary ministers of Holy Communion clear the altar. They may need your assistance to bring the ciborium back.

(S#3-BOOK) approaches near the small table next to the Presider's chair and pick up the sacramentary and standing ready for closing prayer while the Presider is seating.

IV. CONCLUDING RITES

A. CLOSING PRAYER

(S#3-BOOK) goes to the presider when he invites the people with "let us pray" holding for the presider to conclude the liturgy with the closing prayer.

B. BLESSING & DISMISSAL

When the presider is done, place the sacramentary down to the small table and take the liturgical prayer book to assist the Presider in the blessings of the vocational cross family, the extraordinary ministers of Holy Communion and other occasional blessing.

(S#1-CROSS) takes the cross out of the stand and be ready to form in front of the altar with all other altar servers when the Presider approaches the altar for leaving. Line up in front of the altar and be ready to give reverence to the altar before leaving.

V. BEFORE & AFTER MASS

A. Before Mass – be sure to light the candles (if there is baptism at mass light the Paschal candle) and bring two unlighted candle for the procession to the back.

B. After Mass – bring 2 candles to the back of the Church for later Mass' procession and distinguish the light from all candles. Remember to turn the lights in the church down by pushing button #2 at the light switch board.

Preparation for Mass

1. Dress properly. Remember that you will be in the house of God and in the real presence of Jesus. Your shoes should not call attention to themselves or to you. The following footwear are not allowed on the altar:

Flip-flops or beachwear of any kind

Dirty or muddy shoes or sneakers

Sneakers with flashing lights

Plastic, see-through shoes

Untied shoes

Although you will be wearing an alb over your clothes, the alb is white and very bright or very dark colors can be seen through the alb from the pews. Avoid wearing shirts or blouses with any large lettering because people will be able to read what's printed through the alb you're wearing. Also, avoid wearing clothes with very long sleeves or very long pants legs. These will tend to hang outside of your alb. If you fail to dress properly following these guidelines, you may be embarrassed when the priest or the ministry leader refuses to let you serve at Mass.

2. Your hands, including fingernails, and your face should be clean. Older boys must be clean-shaven.

3. Arrive at the church at least 15 minutes before Mass begins. Go immediately to the Bride's Room, check off your name on the schedule, and select an alb to wear.

4. Your alb should be the proper length, with the hem reaching no higher and no lower than the lower part of your ankles. You may roll up the sleeves if necessary, but roll them under, not over the rest of the sleeve. They should reach no higher and no lower than your wrists. The cincture knot of the waist cord is always placed on your left side. The color you should wear will be indicated on the schedule and the calendar. Altar servers wear one of the wooden crosses hanging on the hook. The silver and blue cross is for the captain server to wear. The captain server at each Mass is designated on the schedule with the name underlined.

5. Once you are dressed, one or two of you must light the candles at the altar, the children's liturgy candle and the Easter candle if there will be a baptism during Mass. You can tell by looking at the baptistery if a baptism is planned. If it is set up with a small candle, bib, book, and oil, you should light the Easter candle. This candle is very tall. If you cannot reach it, ask a taller server or any adult to light it for you. The taper should always be used to light the candles. There is a larger taper near the credence table as a backup. You should not light the candles with the electric lighter unless it is absolutely necessary. Go through the Sacristy, up the stairs and to the credence table to retrieve the taper off the hook on the wall. Light the wick and slowly walk out to the altar. Remember to stop and genuflect to the tabernacle before lighting the candles. Extinguish the taper by pulling the wick down through the tube until the flame goes out. Always push the wick back out of the tube after the flame is extinguished. Return the taper to its place on the wall and go immediately through the hall, into the church and wait in the chapel.

6. If you are not one of the servers lighting the candles, you should go to the chapel immediately after dressing. You must be dressed and in the chapel no later than 10 minutes before Mass begins. If you are not there by that time, another server may assume that you have not shown up as scheduled and may take your place. While in the chapel, you may sit or stand quietly. No chatting or talking should be going on. In fact, since you're in the chapel, this would be a good time to say a prayer before Mass.

7. Approximately 2 minutes before Mass begins, you must line up near the gifts table at the beginning of the center aisle. The server carrying the cross is always first in line UNLESS INCENSE IS USED and the rest of altar servers line up behind the cross. This will always be your formation for procession at the beginning of Mass and recession at the end of Mass.

8. The procession begins when the choir and the assembly begin singing the hymn.

Posture During Mass

The easiest way to learn and remember proper posture is to look to Father and the deacons as examples. Copy their postures and you will have no problems.

1. Hands – Your palms should always be together (in a praying posture) whenever walking or kneeling, unless you are holding or carrying something.

2. Walking – Always walk with your back straight and your head held high. Never run in church, especially while wearing your alb!

3. Bowing – When you bow at the altar, bow deeply at the waist and bring yourself slowly to your full height. Never walk and bow at the same time. Stop before bowing. During the procession, watch for Father and the deacons to bow. That's when you will do it as well. The other form of bowing is the head bow. These bows give respect to the President.

4. Genuflecting – This is the process of briefly kneeling on your right knee only. Keep your body upright and slightly pull up your alb before genuflecting, so you won't trip it when straightening back up. Genuflecting is typically only done when entering or leaving the sanctuary when the Blessed Sacrament is in the tabernacle.

5. Kneeling – When you kneel, your body should be upright and your palms should be together, fingers pointing upwards. You may rest your back against the edge of the bench, but do not slouch.

6. Standing – Always stand up straight with both feet firmly on the floor, about 6 to 8 inches apart. This will give you balance and comfort at the same time. Do not lean on the furniture or walls when standing. Stand still and keep your hands together. Do not sway back and forth. Keep both feet on the floor.

7. Sitting – Sit up straight on the bench. You may rest your back against the wall, but do not slouch. Keep your hands folded together in your lap. Never fold your arms while sitting. Do not fidget with your alb, cord, or cross. Never cross your legs while seated on the bench. Never lean on one or both elbows. Avoid scratching, touching your hair, face, or eyes unnecessarily. If you must yawn, sneeze, or cough, remember to cover your mouth with your hand. If you have a runny nose, quickly walk into the Sacristy and use the tissues on the table. Remember to wash your hands at the sink before returning to the altar.

8. Eyes – Always look towards the place where the action is happening during Mass. Whenever the priest, deacon, or lector is speaking, you should be looking at that person, even if it is the back of their head. This is the best way to remain attentive during the Mass and not forget when it's time for you to do your duties. Avoid making eye contact with anyone in the pews or looking at other things in the sanctuary. When everyone sees you being attentive to what is going on at Mass, they may start to do the same.

9. Conduct – Absolutely no unnecessary talking, no laughing, no giggling and no gum chewing is allowed on the altar. Remember to smile and feel free to sing when you know the words. Always recite the responses to the lectors, deacons, Father, the Gloria, Our Father, and other greetings and prayers, just as you would if you were with your parents in the pews. Your participation with the assembly is important like singing the psalm or songs.

At the end of the Mass

As soon as you reach the back of the church, Server #1 places the cross back in its holder on the wall outside the chapel. At least one of the servers goes to the Sacristy, up the stairs and takes the taper to extinguish the candles. You must leave your alb on if you are the one(s) extinguishing the candles. Never walk on the altar without your alb. After extinguishing the candles, that server turns the lights down by pushing #2 switch on the switchboard on the wall by the side of the gopher. The remaining servers go immediately to the Bride's Room to remove their albs. Unless you are returning to put out the candles, you must not walk throughout the church dressed in your alb after Mass. Remember to hang up your alb properly and to return your altar server cross and the cincture cord to their proper places. Check the schedule to find out the next time you are to serve.

Scheduling

The Altar Server schedule will be created and sent to you every two months. Depending on the number of servers available, you will be scheduled to serve at least once a month, possibly more. Newly trained servers will only be scheduled with experienced servers for the first few months. If you are experienced and a new person is serving with you, give that person all the assistance needed. Remember you were once in their place too. If you are a new server, don't be afraid to ask the other servers questions. They will be glad to help you.

Before each Mass, when all the servers have arrived, they decide among themselves which positions or serving part that they will take on the altar. Individual positions are not scheduled. In case there is any dispute among the servers as to who will do what, the Captain Server makes the final decision.

If for any reason you are unable to serve at your scheduled time, you must find your own substitute and you should do so as soon as possible. Before the schedule is created, an e-mail is sent out asking you to provide any dates during the following two months that you will not be able to serve. This prevents you from being scheduled on any of those dates. Do not wait until the last minute to find a substitute and never assume that someone will always fill in for you at the last minute even if you do not find a substitute. There have been several Masses where no servers show up because they thought just that. Do not call the church to let them know you cannot serve. There is nothing Father or the receptionist can do about it. Of course, there are times when something happens at the last minute, like a sudden illness, accident, or death in the family. These are excused absences. When you have three or more unexcused absences, without finding a substitute within a six-month period, you will automatically be suspended from serving. You will have to contact the ministry leader and request to be placed back on the schedule. Attendance is tracked on the schedules themselves.

When you arrive, you should place a check mark next to your name. If you are substituting for a server, you must cross out the scheduled server's name and write your name next to it. Servers who do not show up and do not arrange for a substitute will have their name crossed out and the letter "A" next to their names.

Altar Serving is a volunteer ministry. If at any time, you wish to discontinue serving, you must notify the ministry leader so you will no longer be scheduled. Just dropping out without telling the leader is not fair to anyone, especially to Father and the other servers. As long as you are in this ministry, you must remember to set a good example for other young people and be an inspiration to all parishioners. Just try to be reverent, thoughtful, and well-mannered at all times and people will notice and praise you for serving God in such a wonderful way.